

CHARGE SENSITIVE PREAMPLIFIER — DISCRIMINATOR

A-111



Designed for direct applications in the field of aerospace and portable instrumentation, mass spectrometers, particle detection, imaging, laboratory and research experiments, medical electronics and electro-optical systems.

Model A-111 is a hybrid charge sensitive preamplifier, discriminator, and pulse shaper developed especially for instrumentation employing microchannel plates (MCP), channel electron multipliers (CEM), photomultipliers, proportional counters and other low capacitance charge producing detectors in the pulse counting mode. While this unit was developed for NASA's deep space probes, the following unique characteristics make it equally useful for space, laboratory and commercial applications:

- Small size (TO-8 package) allows mounting close to detector.
- Power required is typically 6 milliwatts.
- Single power supply voltage.
- Output interfaces directly with C-MOS and TTL logic.
- Input threshold is externally adjustable.
- Analog monitor point.
- High reliability process.
- One year warranty.

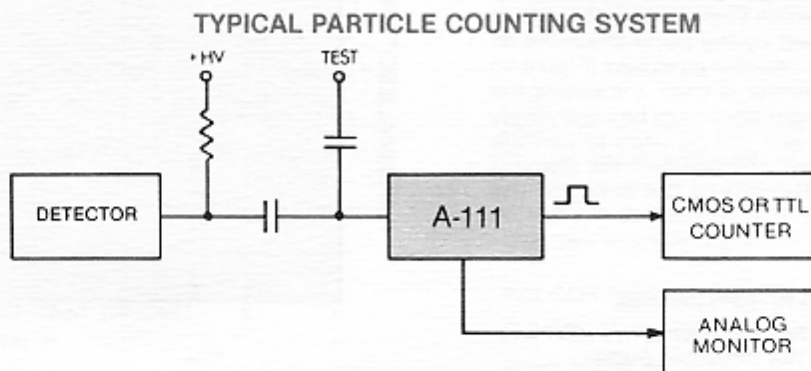

AMPTEK HIGH RELIABILITY SCREENING

- | | |
|------------------------|---|
| 1. PRECAP VISUAL: | MIL-STD-883, method 2017. Low Magnification, High Magnification. |
| 2. SEALING: | Welded, hermetic seal. |
| 3. STAMPING: | Date code and serial number. |
| 4. STABILIZATION BAKE: | MIL-STD-883, method 1008, Condition C. + 150°C, 24 hours minimum. |
| 5. TEMPERATURE CYCLE: | MIL-STD-883, method 1010, Condition C min. T = - 65°C to + 150°C. 10 minutes each extreme, 5 minutes maximum transfer time. |
| 6. CENTRIFUGE: | MIL-STD-883, method 2001, Condition B. YI Axis; 10,000 G's. |
| 7. ELECTRICAL TEST: | As per specifications. |
| 8. BURN-IN TEST: | MIL-STD-883, method 1015, 160 hours at + 125°C. |
| 9. FINE LEAK TEST: | MIL-STD-883, method 1014, Condition A. Rejection if leak rate in excess of 5×10^{-7} cc/sec. |
| 10. GROSS LEAK TEST: | MIL-STD-883, method 1014, Condition C. Fluoro Carbon; Rejection if stream of bubbles is present. |
| 11. ELECTRICAL TEST: | As per specifications. |
| 12. EXTERNAL VISUAL: | MIL-STD-883, method 2009. |

SPECIFICATIONS

($V_S = 5V$, $T = 25^\circ C$)

INPUT CHARACTERISTICS

- THRESHOLD:** Model A-111 has a nominal threshold referred to the input of 8×10^{-15} coulomb. This is equivalent to 5×10^4 electrons. The threshold can be increased by the addition of a resistor between Pins 7 and 8. Shorting these Pins together produces the maximum increase (approximately 10X). See Figure 1.
- STABILITY:** + 5%, - 2% of $25^\circ C$ threshold, 0° to $50^\circ C$.
- THRESHOLD SUPPLY VOLTAGE COEFFICIENT:** - .8%/V typical.
- NOISE:** 4.4×10^{-16} coulombs RMS; 5.5% of nominal threshold.
- DETECTOR CAPACITANCE:** 0-250pf.
- PROTECTION:** 300 ohm resistor in series with input followed by back-to-back diodes to ground.

OUTPUT CHARACTERISTICS

- 1) Pin 5 provides a positive output pulse capable of interfacing directly with CMOS and other logic (see Operating Notes).

Pulse characteristics are:

- RISETIME:** 25ns.
- FALLTIME:** 220ns with $C_L = 5$ pf; 90ns with $C_L = 5$ pf and $R_L = 2K$.
- WIDTH:** 260ns at threshold, 310ns at 10X threshold, with $C_L = 5$ pf.
- AMPLITUDE:** 4.7 volts (approximately 95% of V_S .)
- PROTECTION:** Diodes to ground and V_S .

- 2) Pin 7 provides a positive analog pulse output from the preamplifier section just prior to the discriminator with a rise time of about 100ns. See photo above. At maximum sensitivity (no feedback resistor between Pins 7 and 8) the amplitude of this pulse is proportional to the input charge, $A = 2.5$ V/pC. At threshold this will correspond to a 20 mV pulse. If a feedback resistor is used between Pins 7 and 8, the size of the analog pulse will be divided by the same threshold attenuation factor the feedback resistor produced (Figure 1.) Example: If a 3k Ω feedback resistor is used, the size of the analog pulse will be 1 V/pC. This output must be capacitively coupled to external circuitry and can be used to perform pulse height analysis. Near threshold, however, the shape of the analog pulse will be effected by the firing of the discriminator.

GENERAL

- COUNT RATE:** 2.5×10^6 CPS periodic.
- PULSE PAIR RESOLUTION:** 1) Normal: 350ns; two identical 10X threshold pulses.
2) Overload: 800ns; 100X threshold followed by 10X threshold.
- OPERATING VOLTAGE:** + 4 to + 10 VDC.
- OPERATING CURRENT:** 1.3 ma quiescent.
(typical) 1.4 ma @ 10^5 CPS.
1.9 ma @ 10^6 CPS.
Operating current is essentially independent of V_S .
- TEMPERATURE:** - $55^\circ C$ to + $85^\circ C$ operational.
- SCREENING:** AMPTEK HIGH RELIABILITY (Optional NASA GSFC S-311-P-698)
- WARRANTY:** One year.
- RADIATION RESISTANCE:** > 10^5 Rads
- WEIGHT:** 2.6 g
- PACKAGE:** 12-pin TO-8 case.
- ACCESSORIES:** PC-21 test board.

A-111 TYPICAL WAVEFORMS AT 25X THRESHOLD

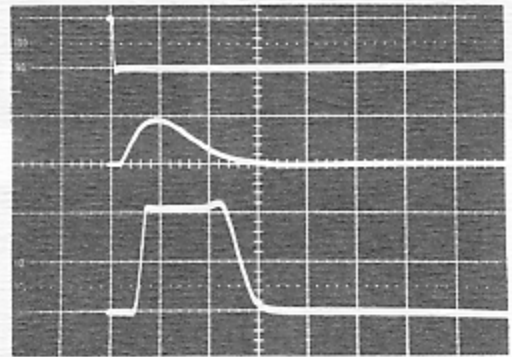

Horizontal = 200 ns/div.

- TOP:** Input test pulse through 2pf capacitor. The A-111 responds during the risetime of the test pulse. Vertical: 100 mv/div.
- MIDDLE:** Analog pulse, Pin 7
Vertical: 0.5 V/div.
- BOTTOM:** Discriminator output, Pin 5, driving a 1K Ω load at $V_S = 5V$
Vertical: 2V/div.

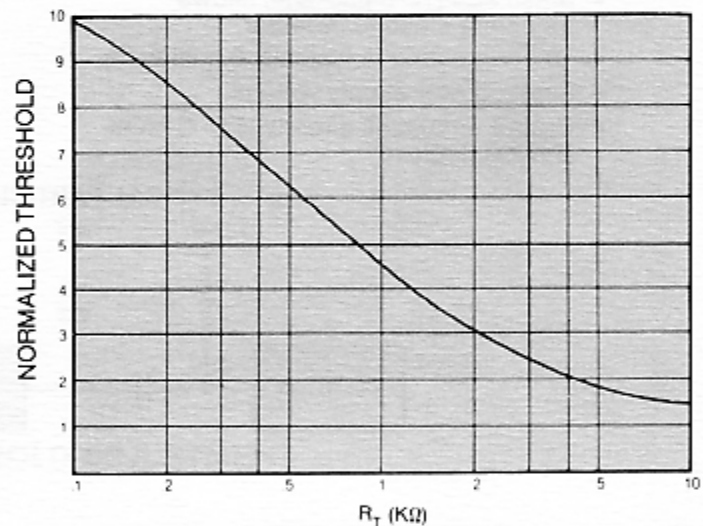

Figure 1 — Threshold vs. R_T

OPERATING NOTES

CIRCUIT LAYOUT

Due to the high sensitivity of the A-111, care should be taken in circuit layout. In general, ground plane construction is recommended, with all ground pins (1, 3, 4, 6, 10, 11 and 9) connected to this plane. Input and output lines should be kept well separated and in most cases shielding will be necessary. Particular attention should be paid to the detector ground connection to avoid multiple pulsing and oscillation due to feedback. The supply voltage is internally decoupled which prevents the A-111 from responding to supply line transients of up to 100mv amplitude. While this is normally adequate, in some applications external bypassing (typically .01 μ f) may be helpful. The PC-21 may be used as an example of appropriate layout techniques.

POWER SUPPLY

While specifications are given for operation at +5V, the characteristics of the A-111 are relatively unaffected by changes in supply voltage from 4 to 18V. Parameters critical to a particular application should be checked at the actual operating voltage.

INPUT

The A-111 has an internal input protection network, including a coupling capacitor, as shown:

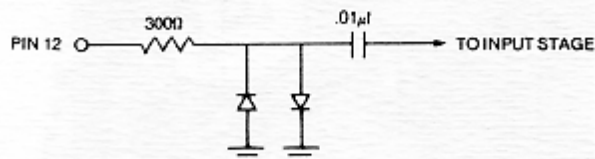

The detector anode should normally be capacitively coupled to Pin 12 with a capacitor of adequate voltage rating. In some applications where the detector cathode is operated at negative potential, the anode can be directly connected to Pin 12.

The A-111 will respond to a negative pulse of 8×10^{-15} coulombs or greater. The threshold may be increased by the connection of a resistor between Pins 7 & 8. Approximate values are given in Figure 1.

While this device is optimized for negative input pulses, it will respond to positive input pulses greater than approximately 2X the negative threshold. Because the specifications provided herein apply to negative input, the user should measure all relevant operating characteristics for any positive-input applications.

The A-111 can be tested with a pulser by using a small capacitor (usually 1 or 2pf) to inject a test charge into the input. The unit will trigger on the negative-going edge of the test pulse, which should have a transition time of less than 20 ns. This negative going edge should be followed by a relatively flat part of the waveform so that it appears as a step function. For example, a square wave is a good test waveform. (When using a square wave, it should be noted that the unit will respond to the positive-going edge also, at amplitudes above 2X threshold). Alternately, a "sawtooth" waveform or a tail pulse with long fall time ($> 1 \mu s$) may be used.

TYPICAL TEST CIRCUIT

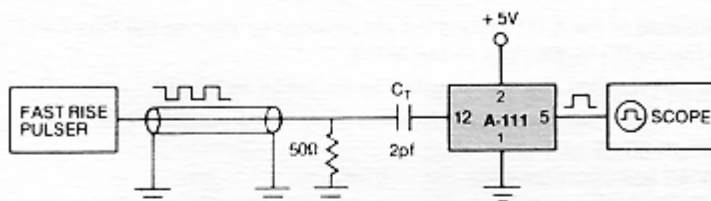

$T_r < 20ns$ (negative-going edge)

Amplitude: 500mv/picocoulomb; 4mv at the nominal threshold.

Charge transfer to the input is according to $Q = C_T V$, where Q = total charge, C_T = value of test capacitor, and V = amplitude of voltage step. DO NOT connect the test pulser to the input directly or through a large capacitor ($> 100pf$) as this can produce a large current in the input transistor and cause irreversible damage.

OUTPUT

The output circuit of the A-111 is a PNP transistor with a 6K collector load to ground:

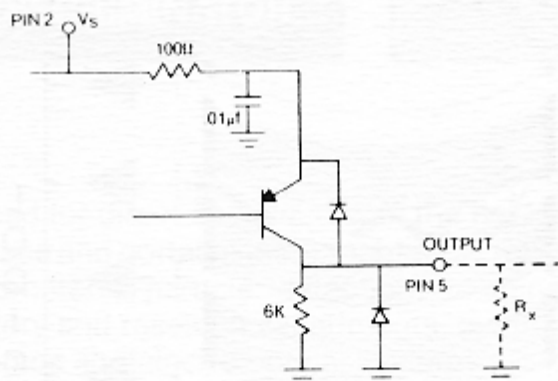

This circuit directly drives CMOS inputs with wide voltage swing and thus excellent noise immunity. The high value (6K) load resistor minimizes both internal ground currents and power consumption in critical applications. In applications where load capacitance is significant and high count rate performance is important, the addition of an external resistor R_x from Pin 5 to ground will shorten the fall time of the output pulse. A typical value for load capacitance of 10-50pf, is 2K. At the expense of pulse amplitude, low impedance circuits may be driven, e.g. terminated coaxial cable. For example, terminated 50 ohm cable can be driven with a pulse amplitude of 1.4 V ($V_S = 5V$).

To interface the A-111 directly with TTL, a value for R_x must be chosen to sink the required low level input current of the TTL device. For example, for low power devices requiring $I_{IN} = .4$ ma at .4V, the maximum value for R_x in parallel with the 6K is 1K. For devices requiring more than 2ma current sinking, an inverting NPN transistor interface between the A-111 and the input is recommended.

GENERAL

Due to its hermetic seal and small size, the A-111 is well suited to use within a vacuum chamber. In such applications care should be taken to avoid electrical discharge near the input which can damage the unit and VOID WARRANTY.

Use care in soldering leads — avoid overheating.

PIN CONFIGURATION

Counter clockwise as viewed from the top

PIN 1, 3, 4, 6, 10, 11	Ground and Case
2	V_S (+4 to +18 VDC)
5	Output
7	Analogue monitor
7 and 8	Threshold adjustment
9	No connection
12	Input

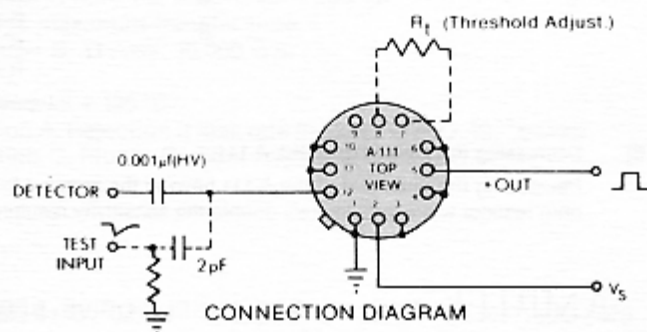

TYPICAL APPLICATIONS

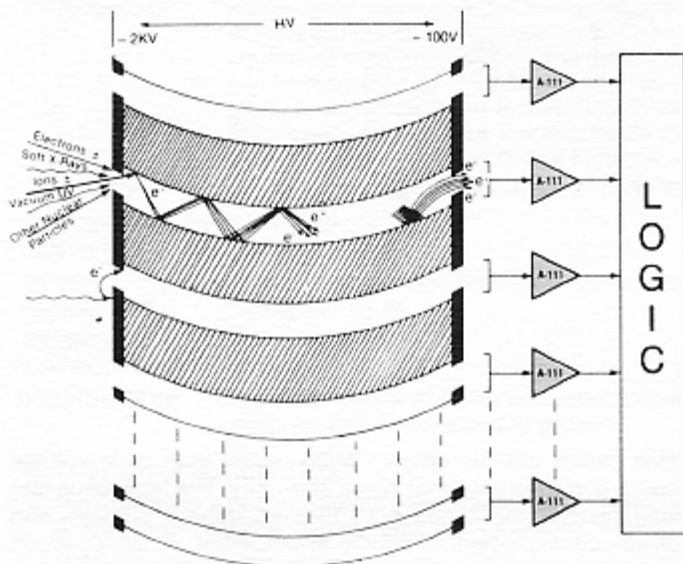

A MICROCHANNEL ARRAY—A-111 CONFIGURATION

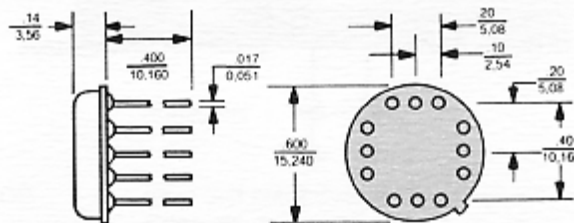

TO-8 TYPICAL DIMENSIONS: $\frac{\text{inches}}{\text{mm}}$

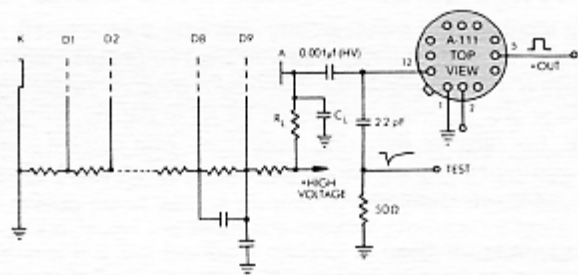

CONNECTION OF A PHOTOMULTIPLIER TUBE TO THE A-111

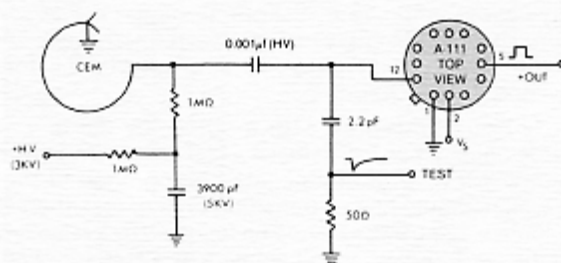

CONNECTION OF CHANNEL ELECTRON MULTIPLIER TO THE A-111.

ADDITIONAL THRESHOLD ADJUSTMENT

A) Increasing the Threshold of the A-111:

Increasing the threshold of the A-111 beyond the $\times 10$ provided by shorting out Pins 7 and 8 can be achieved by an RC feedback as shown at left.

Apart from unit to unit variation, the discrimination levels will be as follows:

1) Shorting out Pins 7 and 8 will result in $\times 10$ increase of nominal threshold: $(5 \times 10^4 \text{ electrons}) \times 10 = 5 \times 10^5 \text{ electrons}$.

2) Shorting out Pins 7 and 8 plus feedback:

R = 50K	C = 2.2pf	: x17
R = 20K	C = 3.3pf	: x23
R = 5K	C = 4.7pf	: x40
R = 2K	C = 6.8pf	: x88

Intermediate values can be obtained by adjusting the value of R.

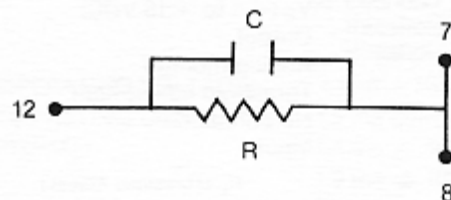

B) Decreasing the Threshold of the A-111:

Decreasing the threshold of the A-111 beyond the nominal 5×10^4 electrons can be achieved by adding a resistor from Pin 8 to ground. A 300 ohm resistor will approximately double the sensitivity resulting in a threshold of 2.5×10^4 electrons.