

Pulse Amplifier

A275



The A275 is a high performance hybrid differential op-amp developed as a pulse amplifier for spaceborne nuclear instrumentation.

Its low power dissipation (15 mW), high slew rate (100 V/μs), and low input noise (4 nV/√Hz), make it ideal for use in a wide range of op-amp applications. The A275 is packaged in a standard 14-pin hybrid DIP.

Features

- Power 15 mW
- Slew rate 100 V/μs
- Input noise 4 nV/√Hz
- Stable DC operation
- 200 MHz gain-bandwidth product
- High reliability screening
- Unity gain stable

Applications

- Space instrumentation
- Portable instrumentation
- Nuclear instrumentation
- Precision active filter design
- Pulse shaping

CONNECTION and PACKAGE DIAGRAMS

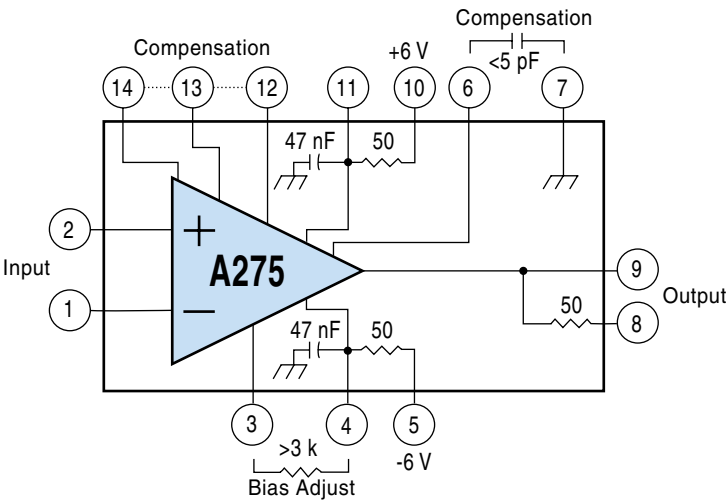

PIN	FUNCTION
1	Inverting input
2	Non-inverting Input
3	Bias adjust to Pin 4, (R>3 kohm)
4	-Vs direct
5	-Vs through 50 ohms
6	Compensation to Pin 7, (C = 0-5 pF)
7	Case and Ground
8	Output through 50 ohms
9	Output direct
10	+Vs through 50 ohms
11	+Vs direct
12,13,14	Compensation: Leave open for gain <10; Short for gain >10

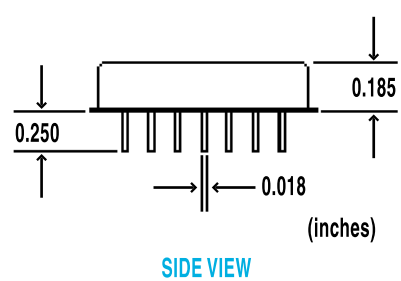
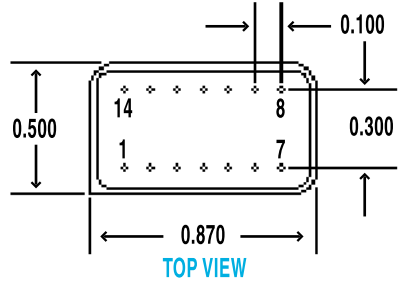

AMPTEK INC.

The A250 Connected to a Solid State Detector with 5 pole shaping and active baseline restoration

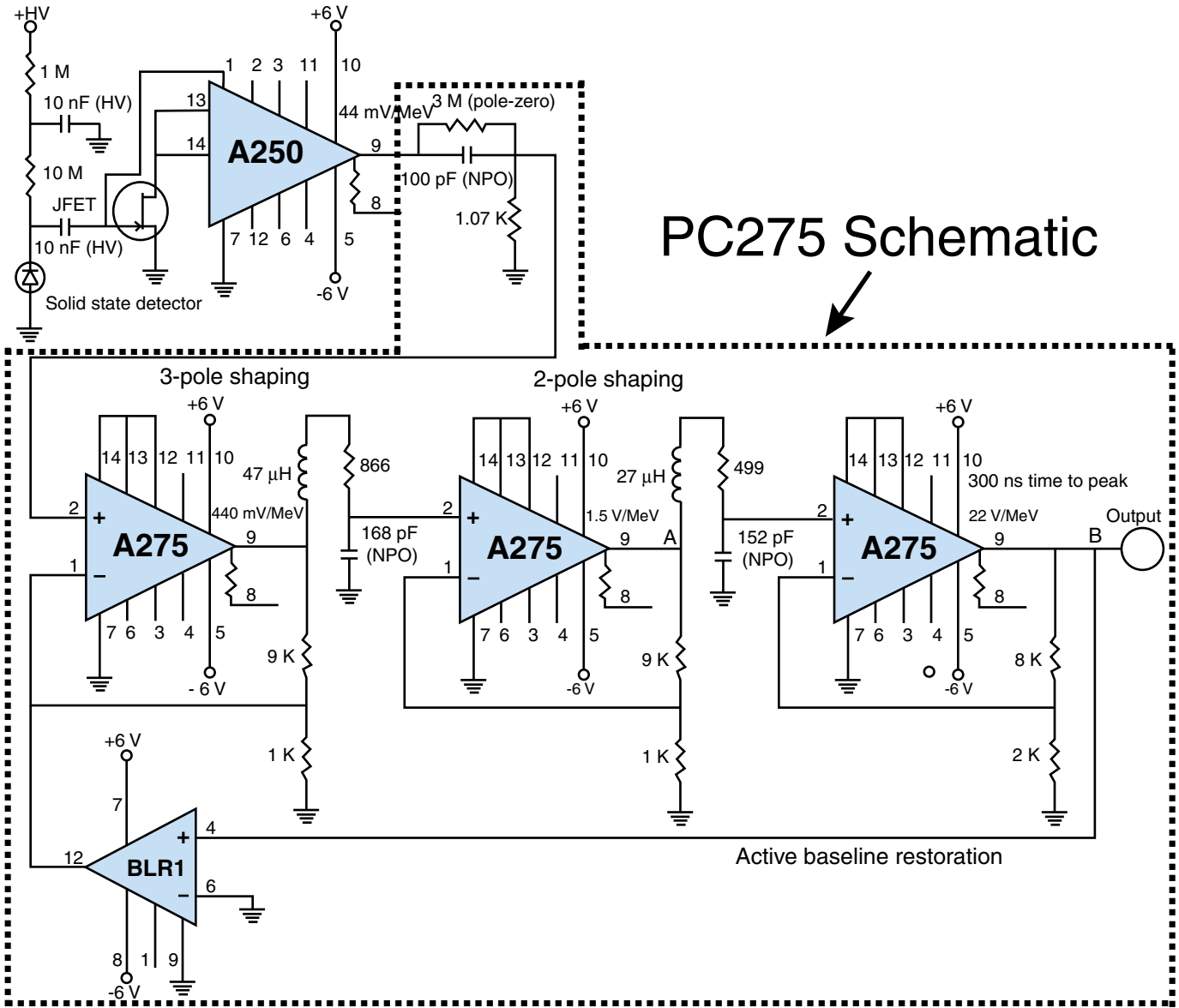

General Case for 3 and 5 Pole Response for Different Peaking Times (Tp)

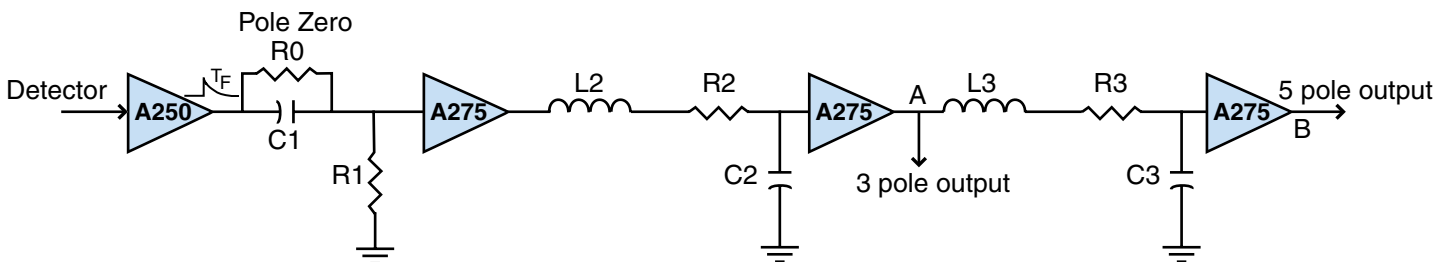

- R1 = 1.07 K
 - R2 = 834
 - R3 = 457
 - R0 = $T_f / C1$
 - C1 = 360 pFxTp
 - C2 = 592 pFxTp
 - C3 = 564 pFxTp
 - L2 = 150 μHxTp
 - L3 = 82 μHxTp
 - Tp = Desired Peaking Time in μs for 5 Pole Response
 - Peaking Time at the 3 Pole Output = (2/3) Tp
- Note: Trim C2 for optimum baseline recovery at "A," then trim C3 for optimum baseline recovery at "B."

OPERATING NOTES

PC275 Input/Output Waveforms

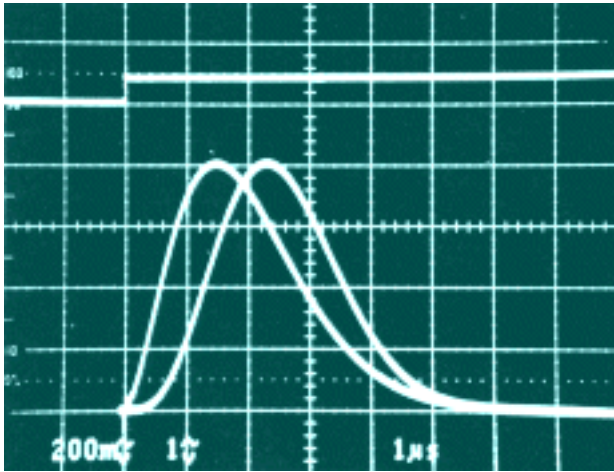

Upper: Input Pulse
 First Output (A): 3 Pole
 Second Output (B): 5 Pole

A275 Gain/Phase

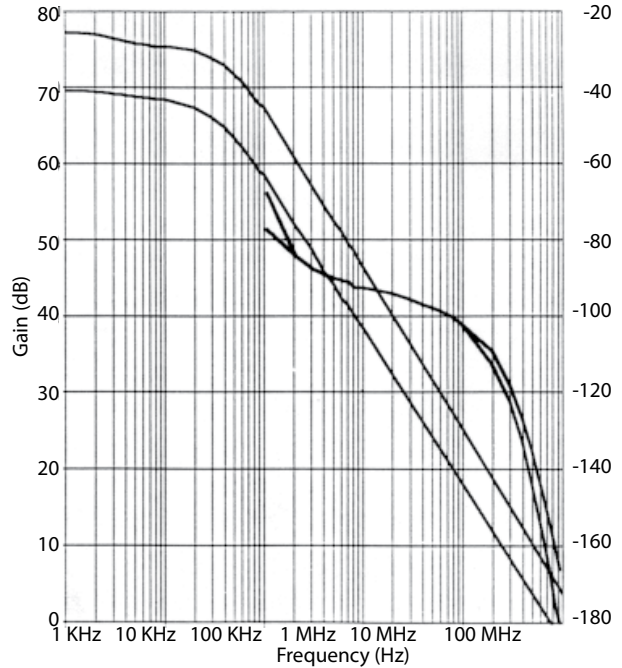

Circuit Layout Considerations

Due to the high bandwidth of the A275, care should be taken in circuit layout. In general, ground plane construction is recommended. Input and output lines should be well separated and in most cases shielding will be necessary. Grounding the physical case of the A275 (in addition to Pin 7) to the ground plane can be used to avoid oscillations or electronic pick-up.

The A275 can be tested as a shaping amplifier by using the circuit shown in the next page. The PC-275 Test Board (shown below) accommodates three (3) A275s and a BLR1 and produces a 5 pole pulse with 1 μ s risetime (2.3 μ s peaking time).

PC-275 TEST BOARD for the A275

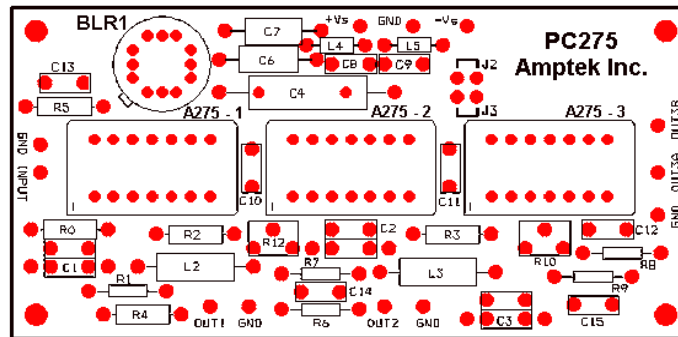

Actual Size

Dimensions: 3.5in x 1.75in (88.9mm x 44.45mm)

A275F

The A275FC and A275FN are high density versions of the Amptek A275 and feature a Single In-line Package (SIP).

Please visit our web site at www.amptek.com for complete details.

For more information visit www.amptek.com

A275 SPECIFICATIONS

Absolute Maximum Ratings

Supply Voltage	±8 V
Input Voltage	±V _S
Operating Temperature	-55°C to +125°C
Storage Temperature	-65°C to +150°C
Lead Temperature Range (Soldering, 10 sec.)	300°C

Electrical Characteristics VS = ±6V, TA = +25°C

PARAMETER	SYMBOL	CONDITIONS	MIN	TYP	MAX	UNITS
Input Offset Voltage	V _{OS}			2	5	mV
Input Offset Current	I _{OS}			0.1	0.6	A
Input Bias Current	I _B			1.5	4	A
Input Capacitance	C _{IN}			4		pF
Differential Input Resistance	R _{IN}			44		k Ohm
Common-Mode Input Resistance	R _{IN}		5	8		M Ohm
Common-Mode Rejection Ratio	CMRR		90	95		dB
Common-Mode Input Range	IVR			±4.5		V
Power Supply Rejection Ratio	PSRR			60		dB
Large-Signal Voltage Gain @5 kHz	A _{LFC}	Compensated	66	68		dB
@5 kHz	A _{LF}	Uncompensated	73	76		dB
@10 MHz	A _{HFC}	Compensated	18	21		dB
@10 MHz	A _{HF}	Uncompensated	26	28		dB
Pulse Risetime (A _V = 10)	t _{rc} t _r	Compensated Uncompensated		15 9	22 15	ns ns
Output Voltage Swing	V _{OP} V _{ON}	Positive Negative	+4.2	+4.4 -5.0	-5.5	V V
Open Loop Output Resistance	R _O			750		Ohm
Output Short-Circuit Current	I _{OSC}	Source Sink		11 -4		mA mA
Slew Rate	S _{RP} S _{RN}	Positive Negative	65 35	100 40		V/s V/s
Input Noise Voltage Density	e _n			4		nV/Hz
Supply Voltage	V _S		±4.5	±6	±8	V
Supply Current	I _S		±1.1	±1.25	±1.4	mA
Power Consumption	P _d			15		mW

General

Package	14 Pin Hybrid DIP
Test Board	PC275
Screening (see web site: www.amptek.com/hybrids.html)	Amptek High Reliability Screening (Standard) Option 1 Option 2
Other Package (see web site: www.amptek.com/A275f.html)	A275FC or A275FN High-density versions of the Amptek A275 in a Single In-line Package (SIP).

